

# Service Information

Already published Service Informations: A01-164 3139 785 30023

## CHANGES DURING PRODUCTION

### FRONT CONTROL BOARD

- \* From production wk204 onwards the following changes are made to improve brightness & reliability of the Blue LED.

3601 change to 33R 5% 0,062W 4822 051 30339

3602 change to 33R 5% 0,062W 4822 051 30339

### ETF TAPE MODULE

- \* From production wk209 onwards a new ETF8 SD Tape Module was introduced replacing the existing ETF6-LE Tape Module. Due to this change the undermentioned changes needs to be implemented together:

#### On the Front Board

7102 is change to 9965 000 11077 TMP88PU74YF.

This is the OTP version of new IC which can be recognized by the "MC50S52881" printed on the body of the IC.

#### On the Center Unit (Refer to Set Exploded view)

Pos 198 is change to 3139 114 73930 Door Cassette

A new Chapter of the ETF8 Tape Module is enclosed. It can be recognized by the the printing mark 3139\_113\_34552\_01 on the pc board.

### 3DTC MODULE

- \* From production wk205 onwards a new pc board pt. 5 is introduced due to the addition of a HF detection circuitry

for other set application. Because the existing module has dedicated circuit diagram for this set, no changes is required on the circuit. Enclosed is the new pt.5 layout.

### COMBI BOARD

- \* From production wk202 onwards a new pc board pt. 2 is introduced to improve GSM immunity & cater for other set application. Due to this new board the following changes are made:

2542 change to 1nF 10% 50V 4822 122 33197

2543 change to 1nF 10% 50V 4822 122 33197

Add 2650 220pF 50V 4822 126 13883

Add 3673 470R 5% 0,1W 4822 051 30471

Add 3674 470R 5% 0,1W 4822 051 30471

Add 4549 0R Jumper 0805 4822 051 20008

Add 5511 Ind. fxd 100MHz 600R 2422 549 44607

Add 5512 Ind. fxd 100MHz 600R 2422 549 44607

The new pt.2 layout & affected circuitry are enclosed for reference.

### REGULATOR BOARD

- \* From production wk212 onwards a new pc board pt. 4 to improve MW/LW sensitivity & noise for other application sharing the pc board. Added on the board are components 2417 and 2420.

The silkscreen printing on the pc board is later changed to pt. 5 to correct item 3433 & 3434 interchange error.

The new pt.5 layout & circuitry is enclosed for reference.



# REGULATOR CIRCUIT

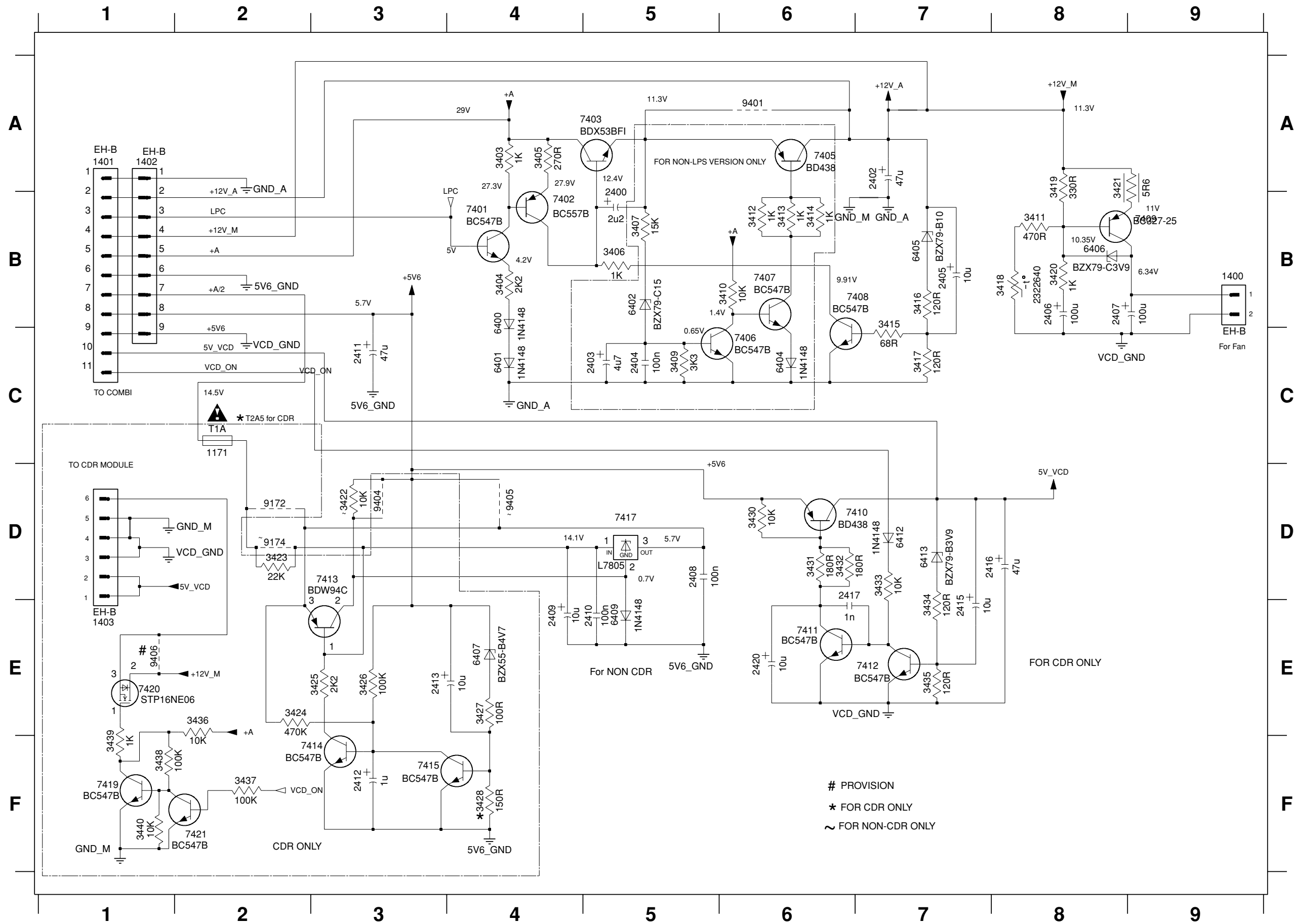

- 1171 C2
- 1400 B9
- 1401 A1
- 1402 A1
- 1403 E1
- 2400 B5
- 2402 A7
- 2403 C5
- 2404 C5
- 2405 B7
- 2406 B8
- 2407 B8
- 2408 D5
- 2409 E4
- 2410 E5
- 2411 C3
- 2412 F3
- 2413 E3
- 2415 E7
- 2416 D8
- 2417 D6
- 2420 E6
- 3403 A4
- 3404 B4
- 3405 A4
- 3406 B5
- 3407 B5
- 3409 C5
- 3410 B6
- 3411 B8
- 3412 B6
- 3413 B6
- 3414 B6
- 3415 B7
- 3416 B7
- 3417 C7
- 3418 B8
- 3419 A8
- 3420 B8
- 3421 A8
- 3422 D3
- 3423 D2
- 3424 E2
- 3425 E3
- 3426 E3
- 3427 E4
- 3428 F4
- 3430 D6
- 3431 D6
- 3432 D6
- 3433 D7
- 3434 E7
- 3435 E7
- 3436 E2
- 3437 F2
- 3438 F1
- 3439 F1
- 3440 F1
- 6400 B4
- 6401 C4
- 6402 B5
- 6404 C6
- 6405 B7
- 6406 B8
- 6407 E4
- 6409 E5
- 6412 D7
- 6413 D7
- 7401 B4
- 7402 B4
- 7403 A4
- 7405 A6
- 7406 C6
- 7407 B6
- 7408 B7
- 7409 B9
- 7410 D7
- 7411 E6
- 7412 E7
- 7413 D3
- 7414 F3
- 7415 F3
- 7417 D5
- 7419 F1
- 7420 E1
- 7421 F2
- 9172 D2
- 9174 D2
- 9401 A6
- 9404 D3
- 9405 D4
- 9406 E1

# PROVISION  
 \* FOR CDR ONLY  
 ~ FOR NON-CDR ONLY



# COMBI COMPONENT LAYOUT

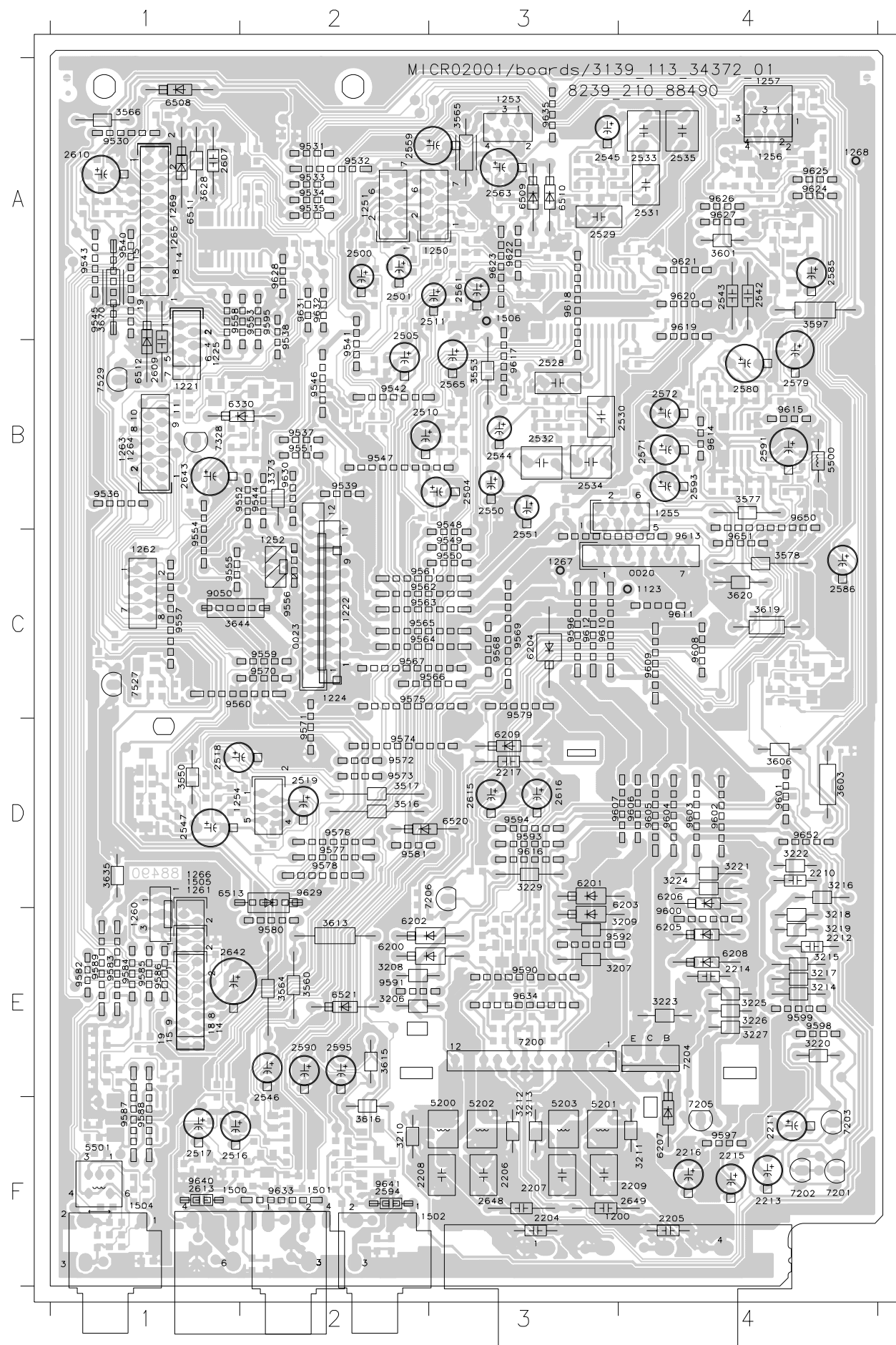

0020	C4	3222	D4	9576	D2
0023	C2	3223	E4	9577	D2
1123	C4	3224	D4	9578	D2
1200	F3	3225	E4	9579	C3
1221	B1	3226	E4	9580	E2
1222	C2	3227	E4	9581	D2
1224	C2	3229	D3	9582	E1
1225	B1	3373	B2	9583	E1
1250	A3	3516	D2	9584	E1
1251	A2	3517	D2	9585	E1
1252	C2	3550	D1	9586	E1
1253	A3	3553	B3	9587	F1
1254	D1	3560	E2	9588	F1
1255	B4	3564	E2	9589	F1
1256	A4	3565	A2	9590	F3
1257	A4	3566	A1	9591	F2
1260	E1	3577	B4	9592	E4
1261	D1	3578	C4	9593	D3
1262	C1	3597	A4	9594	D3
1263	B1	3601	A4	9595	A2
1264	B1	3603	D4	9596	C3
1265	A1	3606	D4	9597	F4
1266	D1	3613	E2	9598	E4
1267	C3	3615	E2	9599	E4
1268	A4	3616	F2	9600	E4
1269	A1	3619	C4	9601	D4
1500	F1	3620	C4	9602	D4
1501	F2	3628	A1	9603	D4
1502	F3	3635	D1	9604	D4
1504	F1	3644	C1	9605	D4
1505	D1	3670	A1	9606	D4
1506	A3	5200	F3	9607	D3
2204	F3	5201	F3	9608	C4
2205	F4	5202	F3	9609	C4
2206	F3	5203	F3	9610	C3
2207	F3	5500	B4	9611	C4
2208	F2	5501	F1	9612	C3
2209	F4	6200	E2	9613	C4
2210	D4	6201	D3	9614	B4
2211	F4	6202	E2	9615	B4
2212	E4	6203	D4	9616	D3
2213	F4	6204	C3	9617	B3
2214	F4	6205	E4	9618	A3
2215	F4	6206	F4	9619	A4
2216	F4	6207	F4	9620	A4
2217	F3	6208	E4	9621	A4
2500	A2	6209	D3	9622	A3
2501	A2	6330	B2	9623	A3
2504	B3	6508	A1	9624	A4
2505	A2	6509	A3	9625	A4
2510	B2	6510	A3	9626	A4
2511	A3	6511	A1	9627	A4
2516	F1	6512	B1	9628	A2
2517	F1	6513	D1	9629	D2
2518	D1	6520	D3	9630	B2
2519	D2	6521	E2	9631	A2
2528	B3	7200	E3	9632	A2
2529	A3	7201	F4	9633	F2
2530	B4	7202	F4	9634	E3
2531	A4	7203	F4	9635	A3
2532	B3	7204	F4	9640	F1
2533	A4	7205	F4	9641	F2
2534	B3	7206	D2	9650	B4
2535	A4	7328	B1	9651	C4
2542	A4	7527	C1	9652	D4
2543	A4	7529	B1		
2544	B3	9050	C1		
2545	A3	9530	A1		
2546	F2	9531	A2		
2547	D1	9532	A2		
2550	B3	9533	A2		
2551	C3	9534	A2		
2559	A2	9535	A2		
2561	A3	9536	B1		
2563	A3	9537	B2		
2565	B3	9538	A2		
2571	B4	9539	B2		
2572	B4	9540	A1		
2579	B4	9541	B2		
2580	B4	9542	B2		
2585	A4	9543	A1		
2586	C4	9544	B2		
2590	E2	9545	A1		
2591	B4	9546	B2		
2593	B4	9547	B2		
2594	F2	9548	B3		
2595	E2	9549	C3		
2607	A1	9550	C3		
2609	B1	9551	B2		
2610	A1	9552	B1		
2613	F1	9553	A2		
2615	D3	9554	C1		
2616	D3	9555	C1		
2642	E1	9556	C2		
2643	B1	9557	C1		
2648	F3	9558	A1		
2649	F4	9559	C2		
3206	E2	9560	C1		
3207	F4	9561	C2		
3208	E2	9562	C2		
3209	F4	9563	C2		
3210	F2	9564	C2		
3211	F4	9565	C2		
3212	F3	9566	C3		
3213	F3	9567	C2		
3214	F4	9568	C3		
3215	F4	9569	C3		
3216	D4	9570	C2		
3217	F4	9571	D2		
3218	F4	9572	D2		
3219	F4	9573	D2		
3220	F4	9574	D2		
3221	D4	9575	C2		

# COMBI CIRCUIT - POWER AMPLIFIER PART

0020 A1	1221 B1	2203 E5	2208 E8	2213 C8	2648 E6	3204 E4	3209 D7	3214 B8	3219 C9	3224 C5	3229 A8	5201 D8	6202 E7	6207 C6	7202 B8	9630 E2
0023 D1	1222 D1	2204 E8	2209 D8	2214 C6	2649 E6	3205 E4	3210 E8	3215 B8	3220 C8	3225 D6	3232 A8	5202 E8	6203 E7	6208 C7	7203 C8	
1123 A2	1224 D1	2205 D8	2210 B9	2215 C5	2650 E8	3206 E7	3211 D8	3216 B9	3221 D7	3226 D6	3233 A8	5203 D8	6204 B6	6209 A9	7204 B6	
1200-A E9	1225 B1	2206 E8	2211 B9	2216 D5	3202 E4	3207 D7	3212 E8	3217 B8	3222 E8	3227 D7	3234 A9	6200 E7	6205 B5	7200 D6	7205 C6	
1200-B E9	2202 E5	2207 E8	2212 C8	2217 A9	3203 D4	3208 E7	3213 D8	3218 B9	3223 C6	3228 A7	5200 E8	6201 E7	6206 C7	7201 B8	7206 A8	

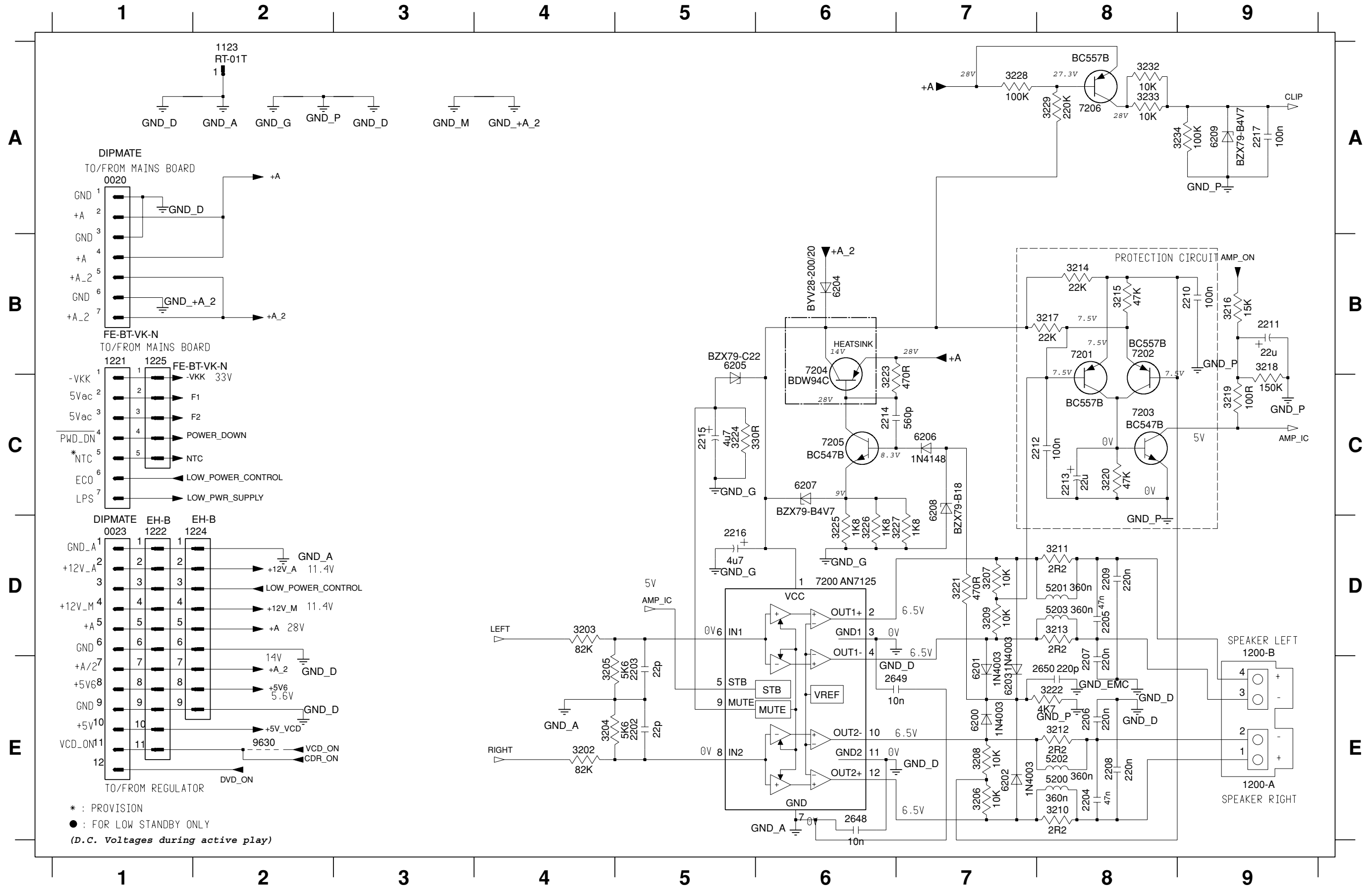

\* : PROVISION  
 ● : FOR LOW STANDBY ONLY  
 (D.C. Voltages during active play)

# COMBI CIRCUIT - SOURCE SELECT & SOUND CONTROL PART

1250 A2	1500-A E1	2501 A5	2508 G3	2513 H2	2518 I5	2523 G9	2528 G13	2533 C14	2538 H16	2543 D16	2548 J11	2560 B8	2566 F11	2645 G15	3503 B5	3508 D4	3513 E4	3518 I2	3523 H3	3530 G14	3535 C16	3541 C12	3546 K10	3553 H9	3559 K11	3566 A3	3671 A5	4505 D13	6508 B4	7501 H3	7500 D11
1251 B2	1500-B G1	2502 C5	2509 F3	2514 I3	2519 H5	2524 G10	2529 D13	2534 G14	2539 C16	2544 H12	2549 K11	2561 B10	2567 F15	2646 C9	3504 C5	3509 E4	3514 G4	3519 H2	3524 I5	3531 D14	3536 H16	3542 H12	3547 J11	3554 H9	3560 H4	3567 B9	3672 B5	4516 I2	6509 B9	7506 K12	9640 I1
1252 D1	1501 E1	2503 B5	2510 F5	2515 H3	2520 G11	2525 G10	2530 G13	2535 G14	2540 H16	2545 C12	2550 H9	2562 B10	2568 F15	2646 C9	3505 C5	3510 F3	3515 F4	3520 J4	3525 H5	3532 D14	3537 C17	3543 C12	3548 K11	3555 H10	3563 I4	3569 D7	3673 F11	5511 E15	6510 C9	7507 K12	
1253 K2	1506 C10	2504 D4	2511 E5	2516 J3	2521 G9	2526 G10	2531 D13	2536 H14	2541 C16	2546 J4	2551 H9	2563 C9	2612 I1	3501 A4	3506 D4	3511 E3	3516 F5	3521 H4	3526 I5	3533 D14	3538 F16	3544 I12	3550 J12	3557 J12	3564 I4	3571 E16	3674 F11	5512 F15	6521 I4	7508 I4	
1254 F6	2500 B5	2505 E4	2512 I2	2517 H3	2522 G11	2527 G10	2532 G14	2537 D15	2542 G16	2547 J11	2559 B3	2565 E11	2613 I1	3502 C5	3507 E4	3512 F4	3517 F5	3522 I3	3527 I5	3534 H16	3539 E17	3545 J10	3552 J12	3558 J11	3565 K3	3572 F16	4504 G13	5513 C2	7500 I3	7509 B9	

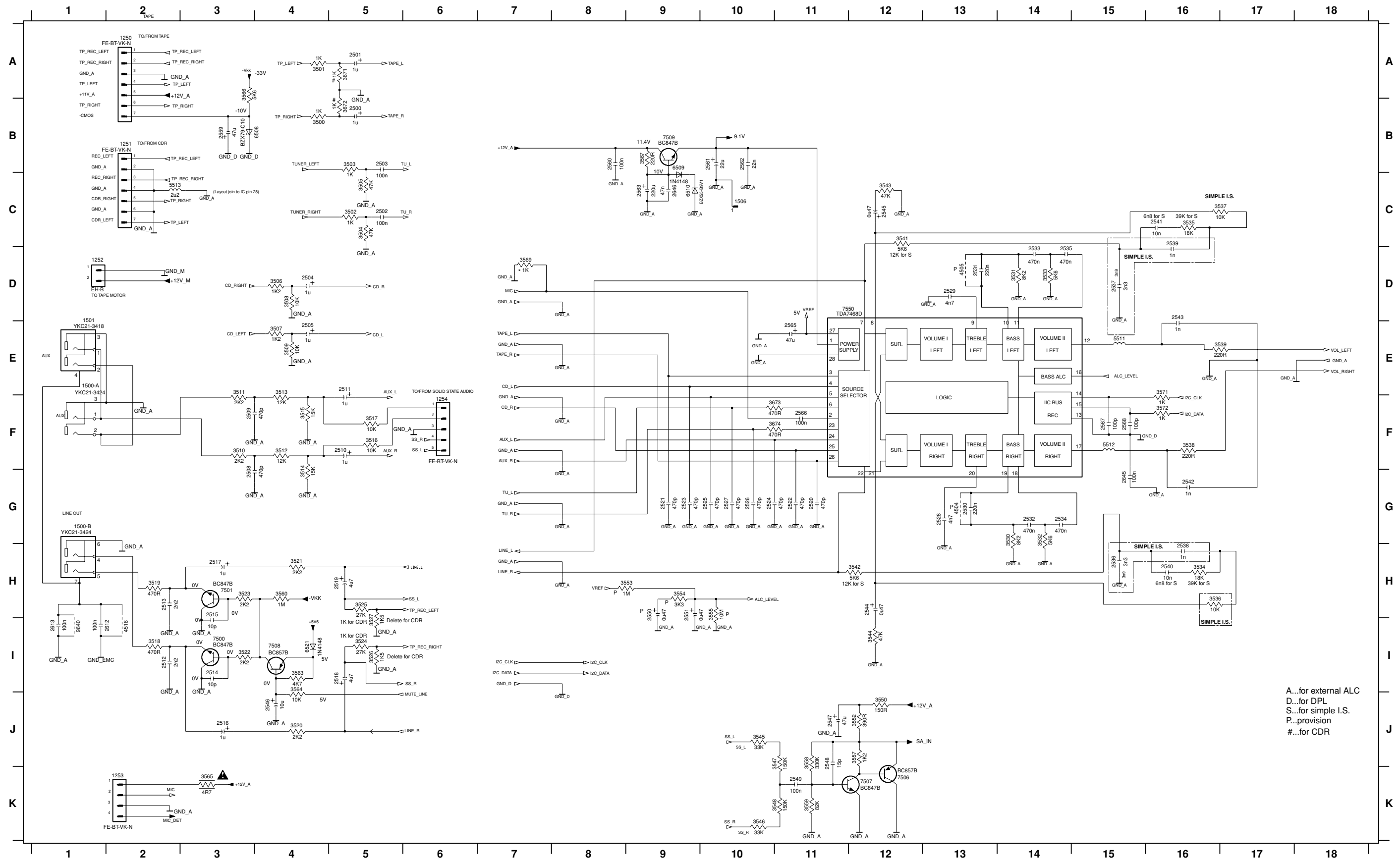

A...for external ALC  
D...for DPL  
S...for simple I.S.  
P...provision  
#...for CDR

# COMBI CIRCUIT - HEADPHONE AMPLIFIER & SUB-WOOFER OUT PART

1255 E1	2571 A3	2575 B4	2579 B6	2585 B9	2589 H6	2593 E2	2615 D11	3575 A3	3579 B3	3583 B5	3589 B7	3593 E12	3597 A7	3601 B10	3605 B13	3610 F11	3614 G6	3618 H7	3641 E13	3646 C13	4600 C12	7510-A A4	7514 D12	7518 B9	7522 G6	7541 E14
1256 C10	2572 C3	2576 C4	2580 D6	2586 B12	2590 H8	2594 G5	2616 C11	3576 C3	3580 D3	3584 B5	3590 D7	3594 C12	3598 A9	3602 B9	3606 B14	3611 G11	3615 G9	3619 E3	3642 D13	4517 F6	4601 D12	7510-B C4	7515 E12	7519 A12	7523 G7	9641 F5
1257 C10	2573 B4	2577 A4	2581 C8	2587 G11	2591 E4	2595 B5	3573 A3	3577 B3	3581 B4	3587 B7	3591 C7	3595 E12	3599 A9	3603 A11	3607 B12	3612 G7	3616 H10	3620 E2	3643 E13	4563 D13	5500 E4	7511 C8	7516 A8	7520 A13	7524 G8	
1502 G5	2574 D4	2578 C4	2582 D8	2588 G11	2592 E4	2614 G6	3574 C3	3578 D3	3582 D4	3588 D7	3592 D7	3596 D12	3600 B8	3604 A13	3609 C13	3613 G8	3617 H6	3621 E2	3645 G7	4576 C13	6520 G10	7512 D8	7517 A9	7521 B13	7540 D14	

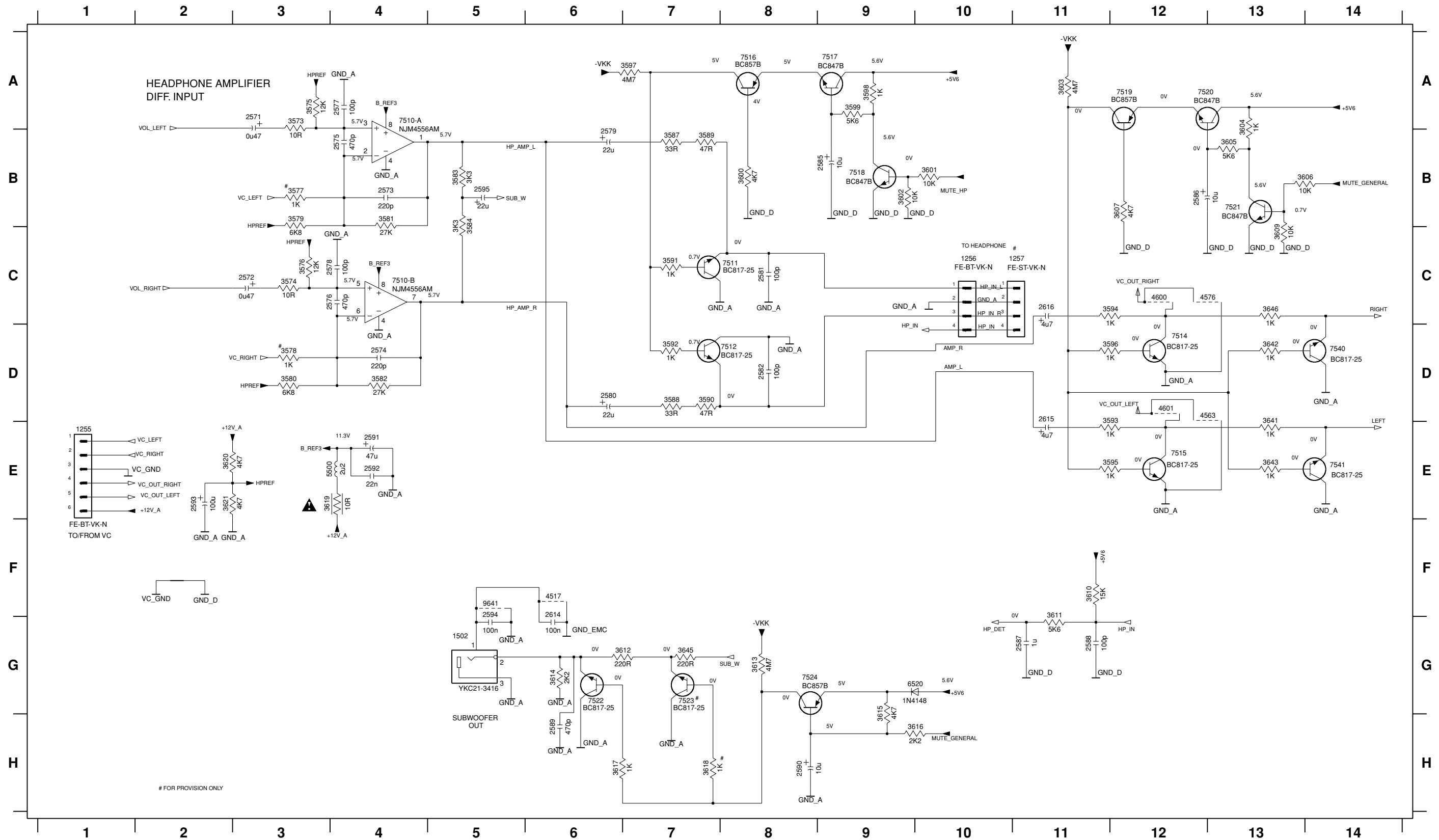

# FOR PROVISION ONLY



# COMBI CIRCUIT - CONNECTOR & DIGITAL OUT PART

1260 C9 1263 F10 1266 A8 1269 D12 2570 B5 2598 B2 2601 B3 2604 C2 2607 E2 2610 G6 2643 C13 3373 E13 3624 A5 3627 D2 3631 F2 3634 G3 3644 A11 3649 B14 3652 A4 3655 E10 4502 E11 4507 D10 4510 G2 4513 A3 4518 F4 4558 G3 6330 D14 6513 F1 7526 D3 7529 F6 7556 C12 9629 F1  
 1261 A9 1264 F9 1267 C1 1504 A1 2596 A3 2599 B3 2602 C4 2605 D2 2608 E2 2611 F8 2647 A4 3622 A4 3625 B4 3628 E2 3632 G2 3635 A3 3647 C14 3650 C13 3653 A4 3656 E10 4503 F11 4508 B11 4511 F3 4514 A3 4519 F4 4559 B5 6511 E1 7328 D13 7527 F2 7553 B12 9050 A11  
 1262 E7 1265 D11 1268 C2 1505 B9 2597 B5 2600 B5 2603 B2 2606 D3 2609 G5 2642 A11 3372 D13 3623 B2 3626 D2 3630 F2 3633 G2 3636 E1 3648 B14 3651 C14 3654 A2 3670 F6 4506 E10 4509 B5 4512 F4 4515 A5 4557 C2 5501 A3 6512 G6 7525 A4 7528 G2 7555 B13 9545 F6

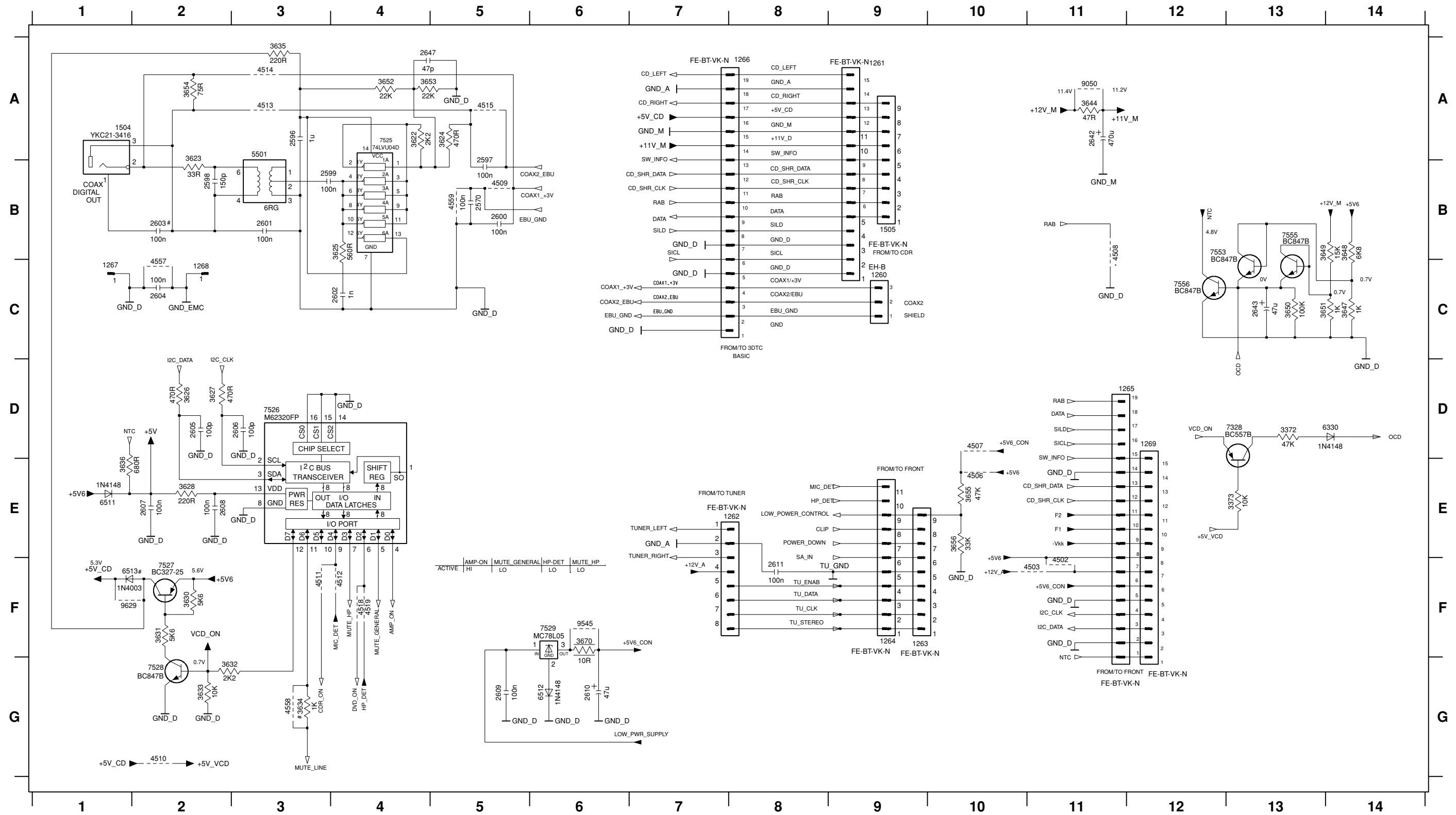

# 3DTC MAIN BOARD LAYOUTS

1800 D1	2818 C5	2863 A6	3887 A5	9804 A2	9824 C1	9833 G2	9843 B3	9854 G5	9864 C7	9875 F6	9885 E7	9894 C4
1801 A4	2830 C2	2864 A7	3888 A5	9805 G7	9825 C1	9834 B1	9844 B2	9855 B4	9865 C7	9876 G6	9886 D7	9895 C5
1802 C4	2839 C3	2866 C6	3899 G1	9806 C3	9826 B3	9836 C1	9845 C3	9856 D2	9866 E7	9877 D7	9887 D7	9896 C1
1803 G5	2843 C2	2868 C5	5800 G5	9807 F5	9827 E1	9837 C1	9847 D3	9857 D2	9869 D7	9878 E7	9888 D2	9897 D6
1804 G2	2845 C4	2886 B5	7802 E2	9808 C7	9828 F1	9838 D3	9848 E3	9858 D3	9870 B7	9879 E7	9889 C5	9898 D6
1805 G3	2847 C3	2891 B6	7803 A6	9809 B7	9829 F1	9839 E7	9849 E3	9859 F4	9871 B7	9880 E7	9890 B4	C800 A1
1806 C7	2851 E2	3779 G4	7815 G3	9821 E1	9830 F2	9840 F6	9850 F4	9860 F4	9872 D7	9882 D5	9891 G7	
2701 G4	2858 E3	3862 D2	9801 F6	9822 E1	9831 F2	9841 F6	9851 F3	9862 D6	9873 F5	9883 D5	9892 F7	
2706 E2	2860 E4	3873 E1	9802 G5	9823 C1	9832 G3	9842 B4	9852 G4	9863 C7	9874 F6	9884 F6	9893 F7	

2700 B3	2816 F4	2846 C2	2878 B5	3701 F2	3727 D6	3745 C5	3761 F5	3778 B3	3795 F2	3818 F4	3848 C6	3864 E3	3880 D3	6804 A2	7811 B7
2703 B3	2817 E5	2848 C3	2879 A4	3702 E6	3728 D5	3746 C5	3762 F6	3780 B1	3796 F3	3820 F2	3849 C6	3865 C6	3881 D3	6805 A2	7812 C5
2704 B2	2819 E4	2849 D3	2880 A5	3703 E6	3729 D6	3747 C5	3763 F5	3781 B3	3797 G2	3821 F4	3850 D6	3866 D4	3882 D3	6806 A2	7813 A2
2705 F2	2820 E4	2850 E3	2881 A5	3713 F3	3730 F2	3748 C5	3764 E6	3782 B3	3805 F4	3829 D2	3851 F1	3867 E3	3883 C3	6807 B1	7814 B2
2707 F3	2821 F2	2852 C4	2882 B5	3715 C6	3731 G3	3750 C5	3765 E5	3783 A7	3806 F4	3830 E2	3852 D6	3868 F3	3884 G7	6808 A1	7816 E5
2710 F3	2822 F4	2853 D3	2885 F6	3716 C6	3733 B7	3751 C5	3766 F3	3784 B2	3807 F1	3831 F2	3853 F2	3869 C3	3885 C3	6809 A1	7817 F2
2711 F2	2828 F2	2854 D3	2887 F6	3717 D6	3735 B7	3752 C4	3768 F3	3785 G2	3808 F4	3833 F4	3854 B6	3870 C4	3886 C4	6810 A1	7818 F2
2712 B3	2829 F3	2855 C2	2888 F5	3718 B6	3736 C6	3753 A6	3770 F3	3786 B1	3809 F1	3835 F2	3855 F2	3871 C2	3889 C3	6811 C2	7819 G2
2713 F3	2831 D5	2856 C3	2889 E6	3719 E5	3737 B5	3754 B6	3771 B3	3787 B3	3810 F4	3836 F1	3856 F2	3872 C4	3890 G6	6812 C1	7820 F3
2810 E4	2832 E2	2859 D3	2890 E5	3720 E5	3738 C5	3755 F6	3772 B2	3788 B2	3811 D2	3840 D6	3857 D6	3874 D3	3891 C3	6813 G3	
2811 F1	2833 D5	2861 G7	2892 E5	3722 F2	3740 C5	3756 F6	3773 A4	3789 B2	3812 D2	3841 C4	3858 D6	3875 E3	3892 F7	6814 G3	
2812 F4	2834 D1	2862 C3	2893 E7	3723 A6	3741 C5	3757 F6	3774 B3	3790 B3	3813 F4	3844 D5	3859 E2	3876 C3	3893 E3	7800 D4	
2813 E4	2836 E2	2865 C3	2894 E5	3724 A6	3742 C5	3758 E5	3775 B3	3791 B3	3814 E5	3845 C5	3860 D6	3877 C3	3897 F3	7801 E2	
2814 F1	2842 E4	2867 E5	2895 E5	3725 B6	3743 C4	3759 E5	3776 A3	3793 F3	3816 E5	3846 C1	3861 E2	3878 C4	6801 B7	7804 D3	
2815 F1	2844 D3	2869 E5	3700 G2	3726 D6	3744 A5	3760 F6	3777 A3	3794 F2	3817 F1	3847 C6	3863 E4	3879 C2	6802 C5	7806 D2	

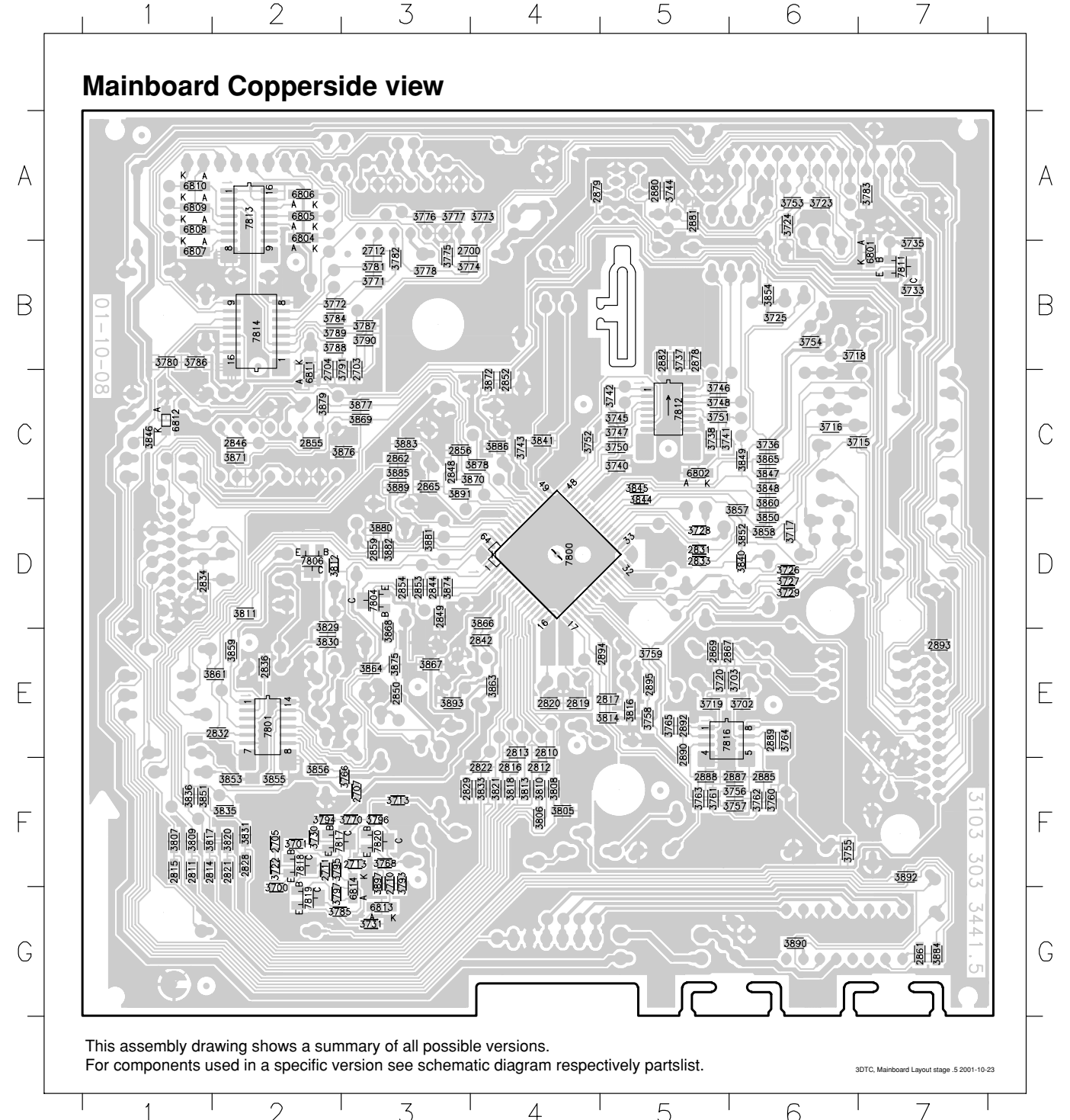
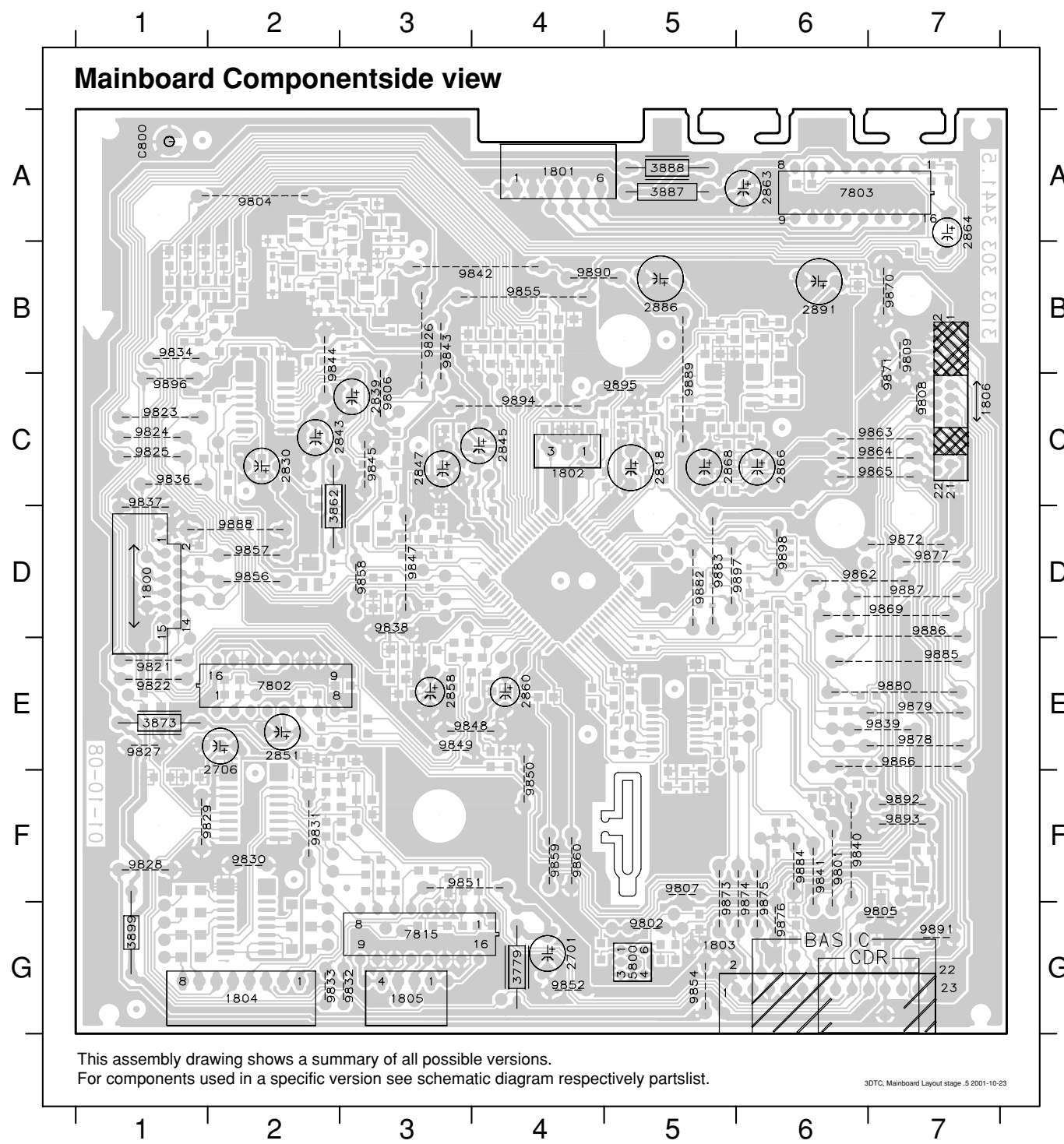

# ETF8 TAPE MODULE

## TABLE OF CONTENTS

Connector assignment .....	9-1
Tape Module Wiring .....	9-2
Tape Mechanism electronics .....	9-2
Tape adjustment / Check Table .....	9-3
HEF4094BT Functional Block & Application Logic Table ...	9-3
ETF8 Board layouts - Components & Chips .....	9-4
ETF8 Circuit diagram .....	9-5
Exploded Views & mechanical parts list .....	9-6
Electrical parts list .....	9-8

## CONNECTORS ASSIGNMENTS:

### CONNECTOR 1701

○	1	REC-L
○	2	REC-R
○	3	GND A
○	4	TAPE-L
○	5	+12V
○	6	TAPE-R
○	7	-CMOS

### INTERCONNECTION TO AF BOARD

Record input left  
Record input right  
AF Ground  
Playback output left  
D.C. supply (+12V) for AF electronics  
Playback output right  
Negative d.c. supply (-9V) for controlling JFET J111

### CONNECTOR 1703

○	1	GND M
○	2	+MOTOR

### INTERCONNECTION TO AF BOARD

Motor Ground  
D.C. supply (+12V) for tape deck motor & solenoid

### CONNECTOR 1706

○	1	CR_IN
○	2	AD1
○	3	+5V
○	4	GND_P
○	5	CLK
○	6	DATA
○	7	STROBE

### INTERCONNECTION TO FRONT BOARD

Deck sensing Chrome Tape  
Deck sensing switches output voltage / Deck EOT  
DC supply (+5V) for deck status ADC network (ref to microprocessor's supply)  
Control & Oscillator Ground  
HEF4094BT shift register Clock line  
HEF4094BT shift register Data line  
HEF4094BT shift register Strobe line

### CONNECTOR 1710

○	1	GND A
○	2	ERASE HEAD
○	3	R/P HD Rch
○	4	Common
○	5	R/P HD Lch

### TAPE HEAD CONNECTIONS

Erase Head ground  
Erase Head  
R/P Head right channel positive  
Pb Head return ground shield  
R/P Head left channel positive

### CONNECTOR 1760

○	1	Vcc 12V
○	2	PHOTO
○	3	GND_M
○	4	MODE
○	5	SoI_supply
○	6	CR_IN
○	7	REC FWD
○	8	REC REW

### DECK CONTROL INTERFACE

Deck / Motor supply  
Photo sensor output (tape movement indication)  
Deck / Motor ground  
Mode switch (head engagement)  
Solenoid supply  
Chrome tape detection switch  
Record tab protection status switch (forward)  
Record tab protection status switch (reverse)

**TAPE DECK WIRING**

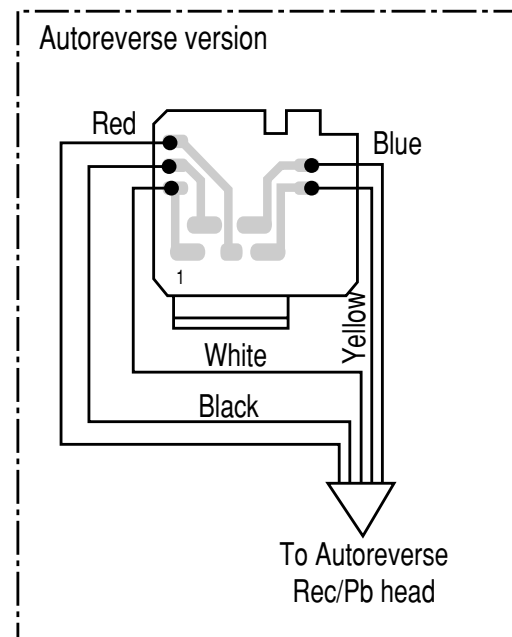
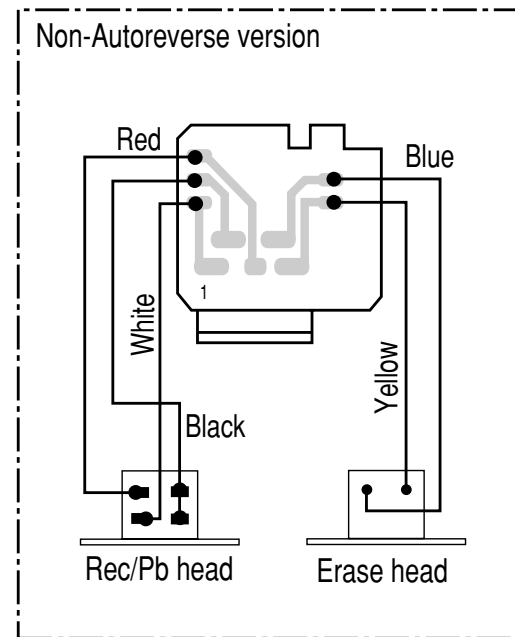
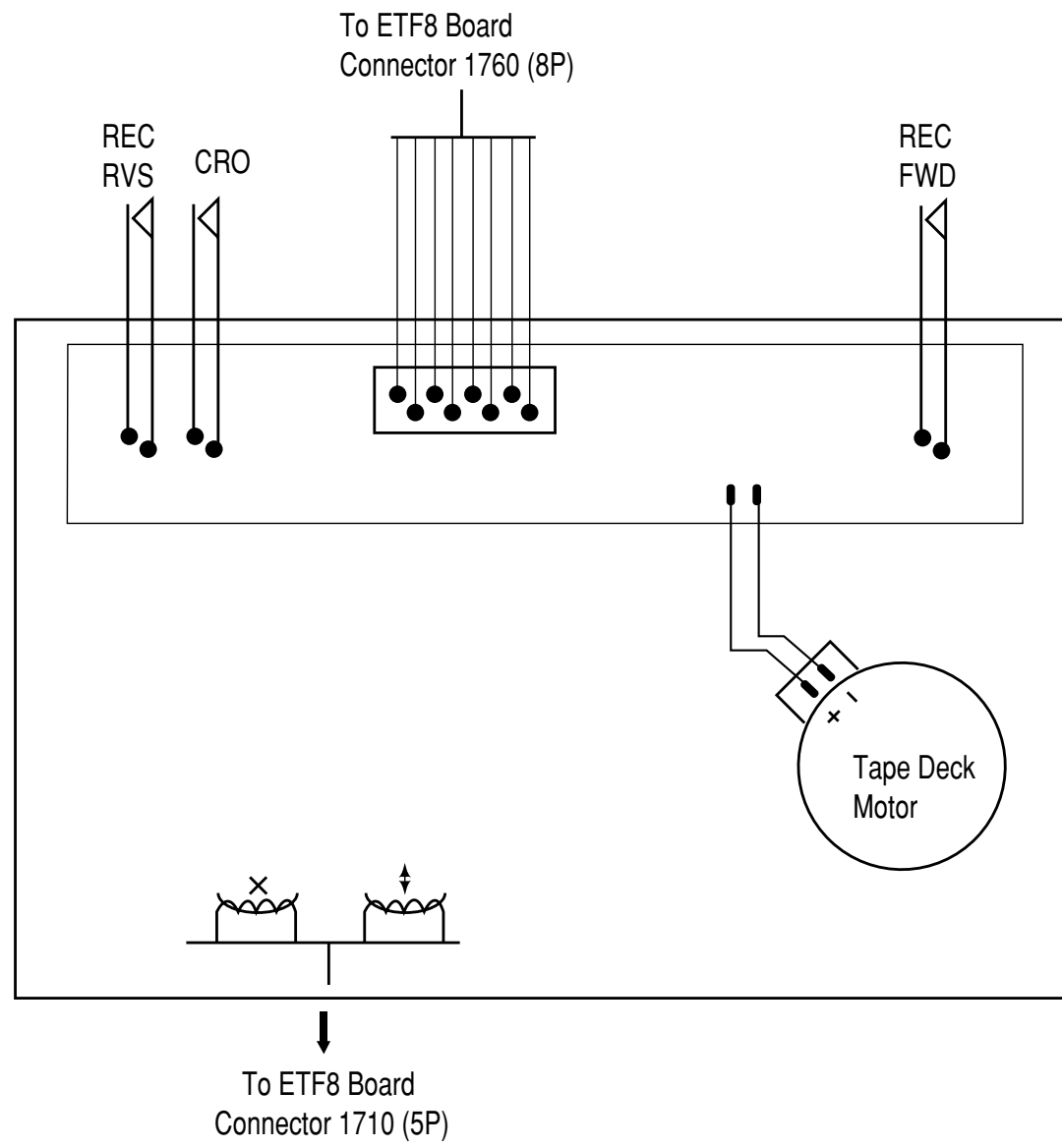

**TAPE MECHANISM ELECTRONICS**

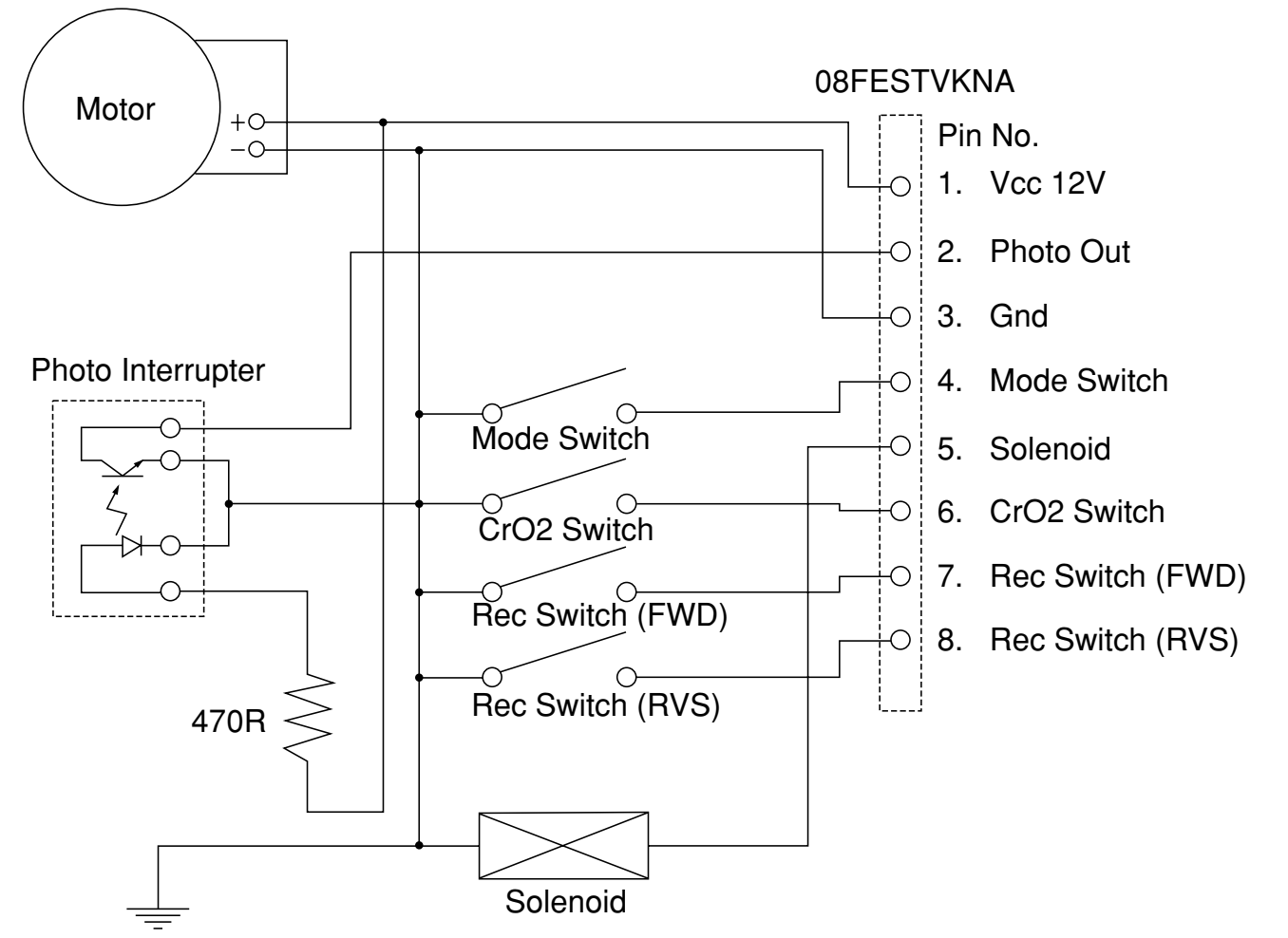

**TAPE ADJUSTMENT & CHECK TABLE**

	TEST CASSETTE	RECORDER MODE	MEASURE ON	READ ON	ADJUST	
					with	to
<b>MOTOR SPEED</b>	SBC420 3150Hz	PLAY		frequency counter	check	3150Hz +/- 2%
<b>WOW &amp; FLUTTER</b>	SBC420 3150Hz	PLAY		W&F-meter	check	< 0.4 % DIN
<b>ADJUST AZIMUTH</b>	SBC420 10kHz	PLAY FWD	1 or 2 LEFT RIGHT	mV-meter	left hand screw	max. output level & left=right
		PLAY REV ^			right hand screw	
<b>PLAYBACK FREQ. RESPONSE</b>	SBC420	PLAY		mV-meter	check	limits see fig. 1 *
<b>CHECK RECORD/PLAYBACK FREQUENCY AND DISTORTION</b>						
Inject 8.85mV signals 100Hz, 250Hz, 1kHz, 10kHz, 12.5kHz via 3 or 4	SBC419A or SBC420	RECORD				
	RECORDED CASSETTE	PLAY	1 or 2 LEFT RIGHT	mV-meter	check	limits see fig. 2 *
Inject 1kHz 28mV via 3 or 4	SBC419A or SBC420	RECORD				
	RECORDED CASSETTE	PLAY	1 or 2 LEFT RIGHT	THD-meter	check	< 3% *

SBC419A : 4822 397 30069  
SBC420 : 4822 397 30071

^ For Auto-reverse version only  
\* If high frequencies are not within limits, decrease bias and re-measure.  
If distortion is too high, increase bias and re-measure

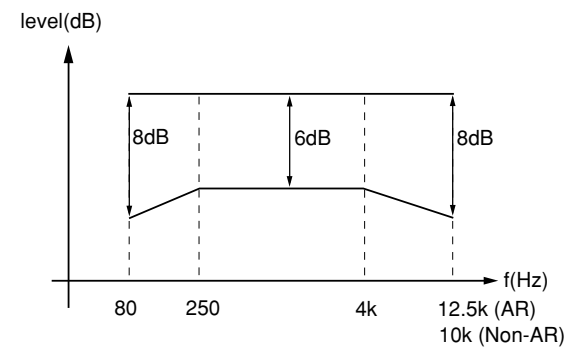

figure. 1

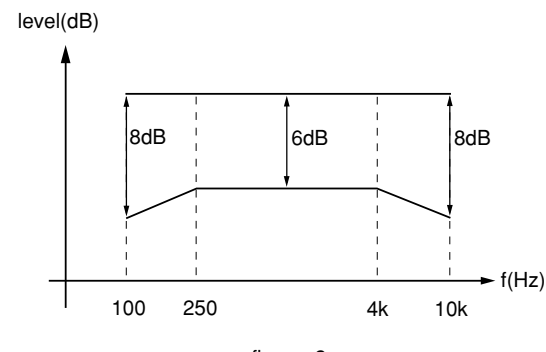
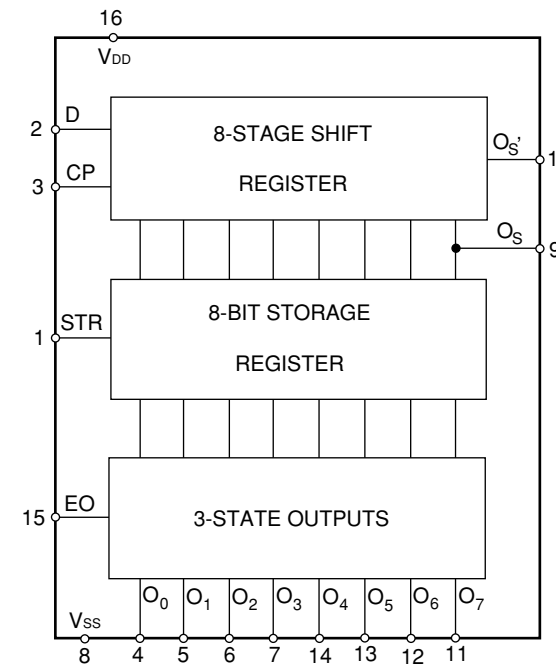

figure. 2

**HEF4094BT FUNCTIONAL BLOCK DIAGRAM**



**AF Control Logic State Table**

State of Module	Control lines from HEF4094BT							
	O <sub>0</sub>	O <sub>1</sub>	O <sub>2</sub>	O <sub>3</sub>	O <sub>4</sub>	O <sub>5</sub>	O <sub>6</sub>	O <sub>7</sub>
	CR_SEL	REC	BIAS_OFF	CR_BIAS		SOL	MUTE_OFF	MOT
Stop	0	0	1	X	Not in used	Deck Mechanism Timing	0	0
Playback (Ferro)	0	0	1	0			1	1
Playback (Chrome)	1	0	1	1			1	1
Record (Ferro)	0	1	0	0			0	1
Record (Chrome)	1	1	0	1			0	1
FWD	0	0	1	X			0	1
REW	0	0	1	X			0	1

Note: 0 = Logic Low  
1 = Logic High  
X = Not applicable

### COMPONENT LAYOUT

1701 A3	2715 A5	2795 B3	6612 A2	6777 D2	9704 C4
1703 A1	2716 B5	2796 C3	6770 D3	6778 D2	9705 B5
1706 C2	2761 A3	2797 B4	6771 D3	7782 D4	9706 C4
1710 A5	2768 A2	2798 A3	6772 C4	7786 B5	
1760 A1	2780 C1	3778 C3	6773 C4	9701 C3	
2713 A4	2784 C5	5701 A5	6774 D4	9702 C2	
2714 C3	2785 C3	5703 D5	6776 D2	9703 A5	

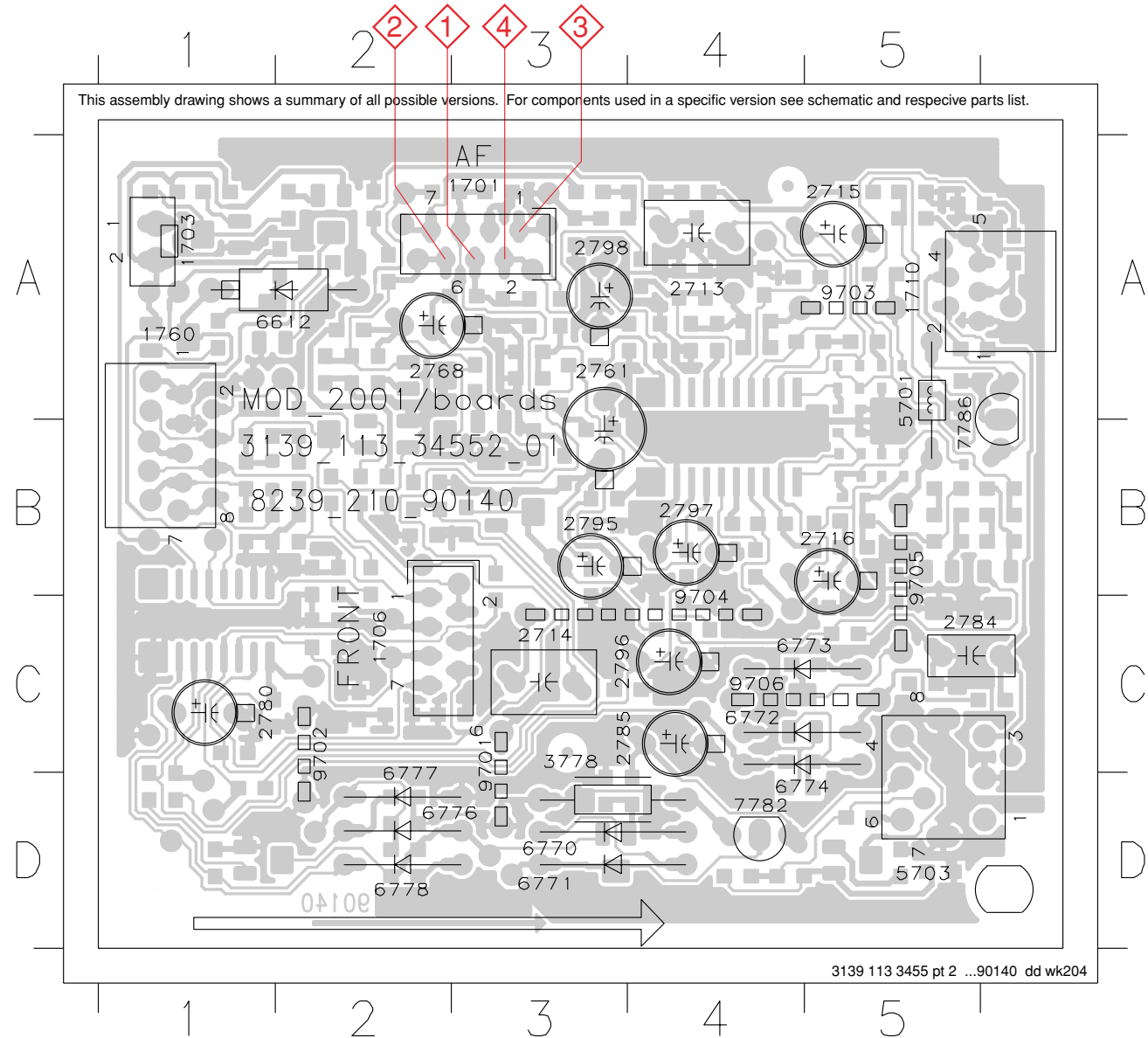

### CHIP LAYOUT

2621 C5	2732 A1	3630 A4	3745 B4	3796 A2	4735 A2
2622 C5	2743 C1	3678 A5	3746 A4	3797 B4	4736 B1
2623 C4	2747 A3	3680 A4	3749 A1	3800 D5	4737 A2
2625 B4	2769 A3	3686 B4	3750 A1	4701 A4	4738 B1
2701 A1	2770 A4	3709 A1	3762 D4	4702 B4	4739 A1
2702 A1	2781 D1	3710 B1	3764 B3	4705 A3	4741 A3
2703 A3	2782 D2	3711 A1	3768 A3	4707 C3	4746 A1
2704 A2	2786 C1	3712 B1	3769 D4	4708 A3	4747 A1
2709 A1	2787 D2	3717 A2	3770 D2	4709 B4	7610 C5
2710 B1	2788 A3	3718 B1	3771 D3	4710 C4	7612 A4
2711 A2	2789 A2	3719 B1	3772 D5	4711 B4	7614 A5
2712 B4	2790 B2	3720 B1	3774 D4	4712 B4	7618 A5
2717 A2	2791 A1	3721 B1	3775 D1	4718 C2	7620 A5
2718 B1	2793 A1	3722 B1	3776 D2	4719 B3	7624 B4
2719 B1	2794 B1	3723 A1	3777 D1	4720 C2	7720 B2
2720 B1	2799 B3	3724 B1	3779 C2	4721 C2	7780 D5
2721 A2	3607 B5	3733 A3	3780 C1	4723 B4	7781 D1
2722 B2	3608 B5	3734 A2	3781 A2	4725 B3	7783 D3
2723 A2	3609 B5	3735 A3	3786 D5	4726 B3	7784 C1
2724 B1	3610 B5	3736 A2	3789 D4	4727 C4	7788 B4
2725 A4	3611 B5	3737 A3	3790 A3	4729 B2	7789 B3
2727 A1	3612 B5	3738 A4	3791 C2	4730 B2	7790 A4
2728 B1	3614 B4	3739 A4	3792 D5	4731 C4	7792 B3
2729 A1	3624 A4	3740 B4	3793 B3	4732 A2	7793 B1
2730 B1	3626 A5	3743 A3	3794 B1	4733 B3	7794 B1
2731 A1	3628 A5	3744 A4	3795 C1	4734 B3	

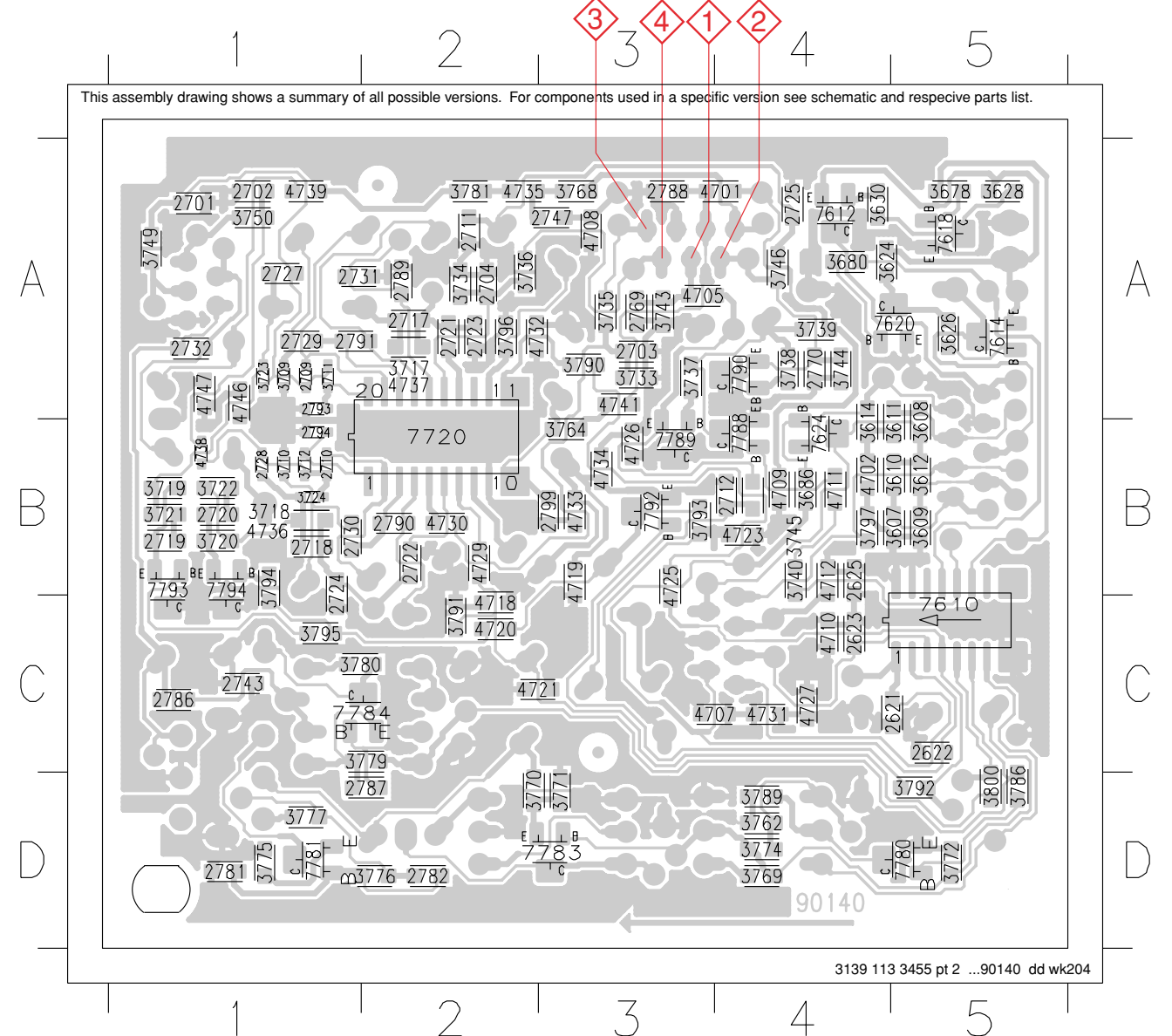

# CIRCUIT DIAGRAM

1701 D14	2621 A3	2702 E3	2711 D9	2716 H8	2721 D7	2727 D3	2732 G2	2769 E12	2784 I1	2789 E8	2795 G5	3607 A11	3612 B11	3630 A9	3710 I8	3719 E4	3724 E3	3737 G13	3744 F11	3762 H2	3771 I3	3777 I2	3786 I5	3793 F5	3800 G11	6612 A10	6774 G3	7612 A9	7720 F8	7784 G3	7792 F6
1703 A1	2622 A3	2703 E13	2712 I8	2717 D5	2722 H7	2728 E3	2743 I1	2770 F11	2785 I2	2790 G8	2796 G9	3608 B10	3614 C11	3678 B8	3711 E7	3720 E4	3733 E3	3738 G12	3764 F9	3772 I3	3778 H1	3789 I4	3794 F5	4736 D5	6770 H2	6776 I4	7614 A10	7780 I4	7786 G2	7793 F4	
1706 A1	2623 A2	2704 F12	2713 D9	2718 E5	2723 D7	2729 E8	2747 D13	2780 I3	2786 G1	2791 E8	2797 G9	3609 A11	3624 A9	3680 B9	3712 G7	3721 E4	3734 F13	3739 G13	3746 D11	3768 D13	3774 H3	3779 G3	3790 D9	3795 F5	4737 D5	6771 H2	6777 H3	7618 B9	7781 I3	7788 G13	7794 F4
1710 F1	2625 C5	2709 E7	2714 H8	2719 F4	2724 H7	2730 H8	2761 F10	2781 I3	2787 G3	2793 F7	2798 E9	3610 B11	3626 A10	3686 C11	3717 D5	3722 E4	3735 E13	3740 G14	3749 D2	3769 H5	3775 I3	3780 G2	3791 G9	3796 E10	5701 G2	6772 G1	6778 H5	7620 B9	7782 H2	7789 G12	
1760 A14	2701 D2	2710 G7	2715 D8	2720 F4	2725 D10	2731 E9	2768 G13	2782 I2	2788 D13	2794 G8	2799 F10	3611 A10	3628 A9	3709 D8	3718 E5	3723 D3	3736 E13	3743 E12	3750 E2	3770 I2	3776 I2	3781 G2	3792 F6	3797 C11	5703 I1	6773 G2	7610 B5	7624 C11	7783 H2	7790 G12	

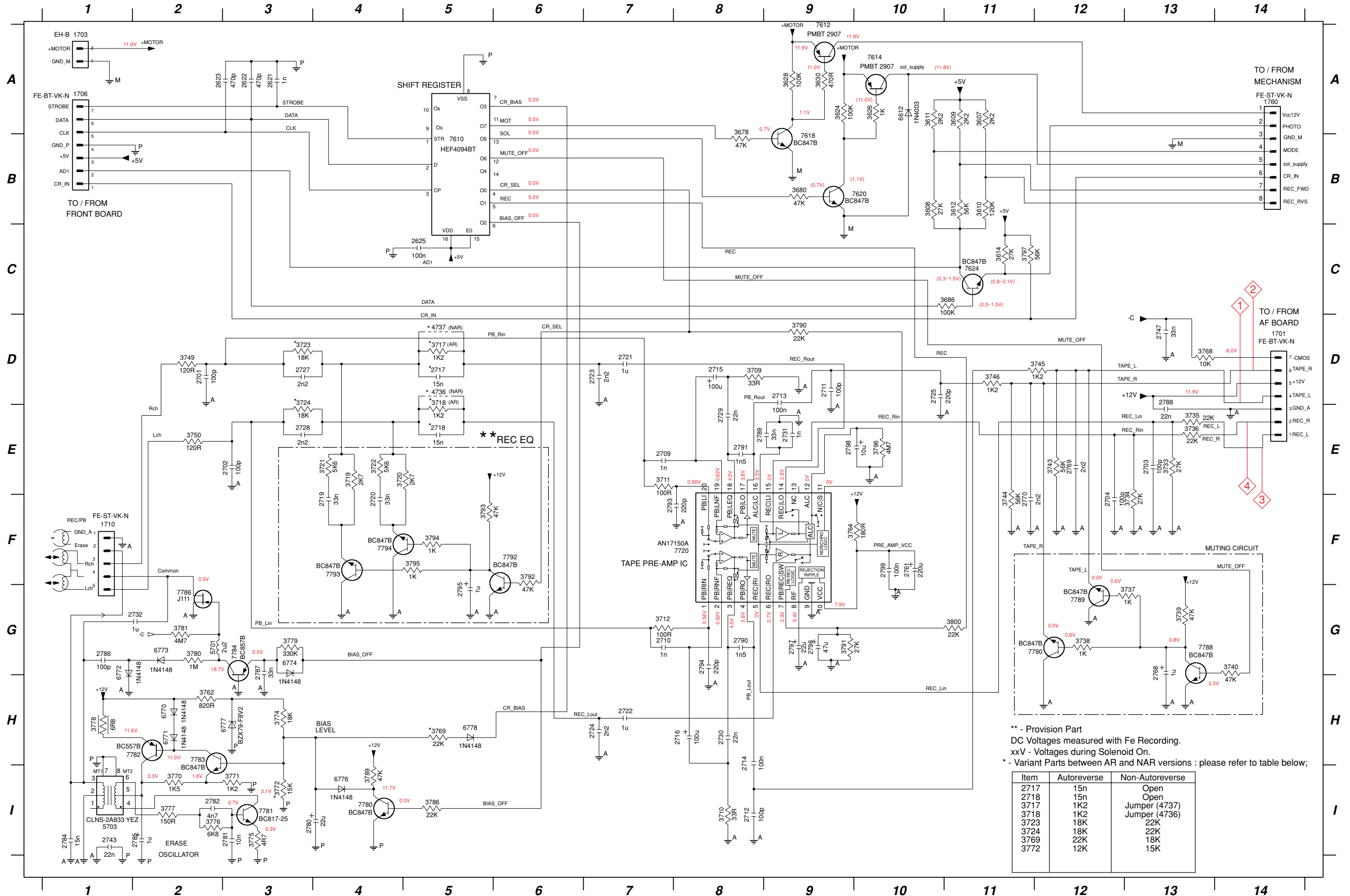

\*\* - Provision Part  
 DC Voltages measured with Fe Recording.  
 xxV - Voltages during Solenoid On.  
 \* - Variant Parts between AR and NAR versions : please refer to table below;

Item	Autoreverse	Non-Autoreverse
2717	15n	Open
2718	15n	Open
3717	1K2	Jumper (4737)
3718	1K2	Jumper (4736)
3723	18K	22K
3724	18K	22K
3769	22K	18K
3772	12K	15K



# AUTOREVERSE (AR) TAPE MECHANISM

## MECHANICAL PARTS LIST - AUTOREVERSE TAPE MECHANISM

1	9965 000 10041	Rec/Pb Head assembly
7	9965 000 10042	Cap Pinch R
8	9965 000 10043	Cap Pinch L
9	9965 000 10044	Roller Pinch
32	9965 000 10045	Solenoid assembly
34	9965 000 10046	Motor Assembly
36	9965 000 07441	Belt-SR
37	9965 000 07442	Belt-FR
39	9965 000 10047	Flex Socket 5pin Hort.
40-2	9965 000 10048	Flex Socket 8pin Hort.
40-3	9965 000 10049	Mode Switch
40-4	4822 116 83883	470R 5% 0,5W
40-5	9965 000 10050	Spacer
40-6	9965 000 10051	Photo Interrupter
40-7	9965 000 07443	Box Switch
40-8	9965 000 10052	Spring Sw
61	9965 000 10053	Spring
62	9965 000 10054	Spring

Note: Only the parts mentioned in this list are normal service spare parts.

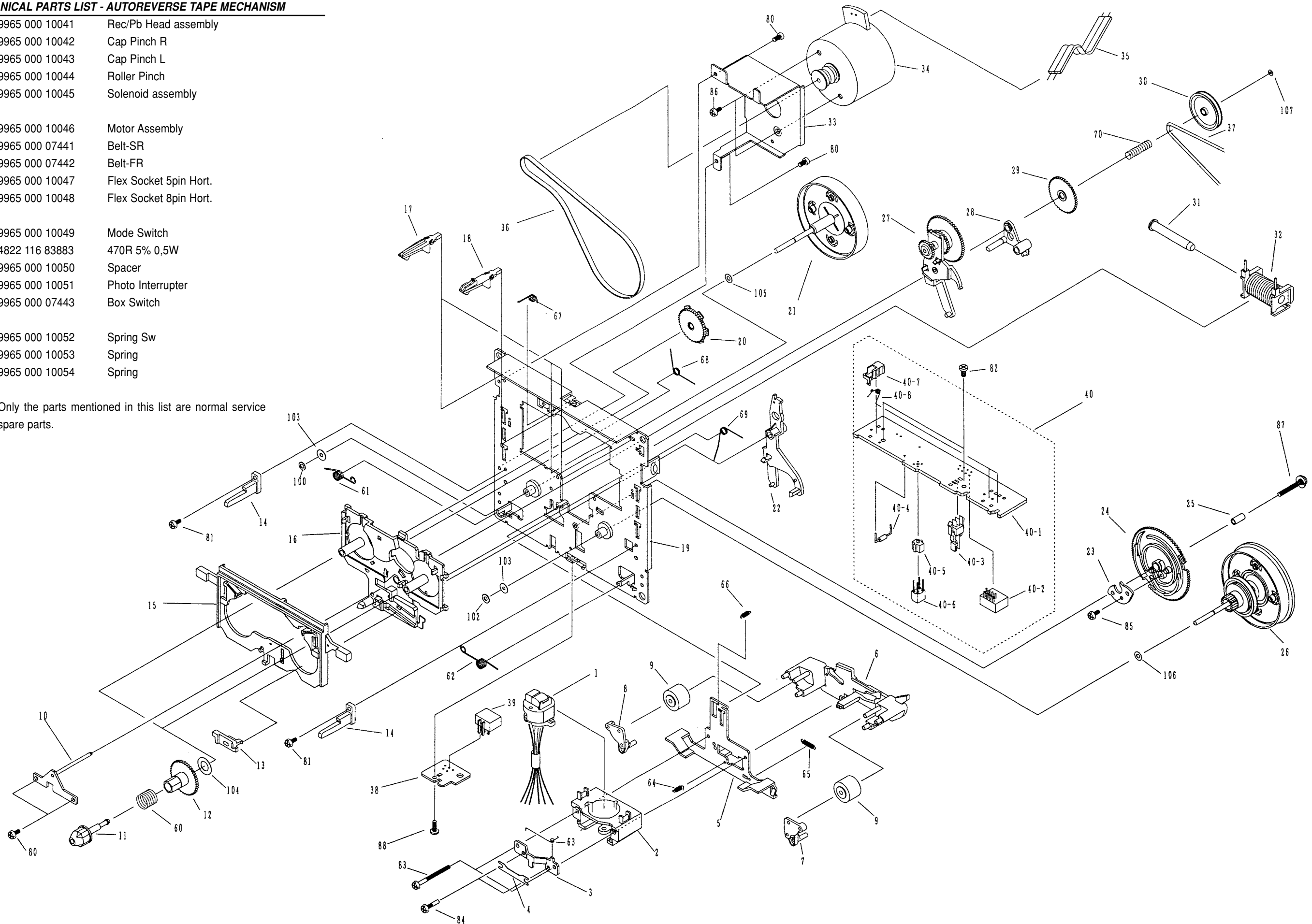



### NON-AUTOREVERSE (NAR) TAPE MECHANISM

**MECHANICAL PARTS LIST - NON-AUTOREVERSE TAPE MECHANISM**

1	9965 000 12110	Play Head
2	9965 000 02600	Erase Head
7	9965 000 10042	Cap Pinch Roller
9	9965 000 10044	Roller Pinch
32	9965 000 07439	Solenoid Assy
34	9965 000 10046	Assembly Motor
36	9965 000 12114	Belt SF
37	9965 000 07442	Belt FR
39	9965 000 12115	Flex Socket 5pin Hort.
40-2	4822 265 11535	Flex Socket 8pin Hort.
40-3	9965 000 10049	Mode Switch
40-4	4822 116 83883	470R 5% 0,5W
40-5	9965 000 12116	Spacer
40-6	9965 000 10051	Photo Interrupter
40-7	9965 000 07443	Box Switch
40-8	9965 000 10052	Spring Sw
61	9965 000 10053	Spring
62	9965 000 10054	Spring

Note: Only the parts mentioned in this list are normal service spare parts.

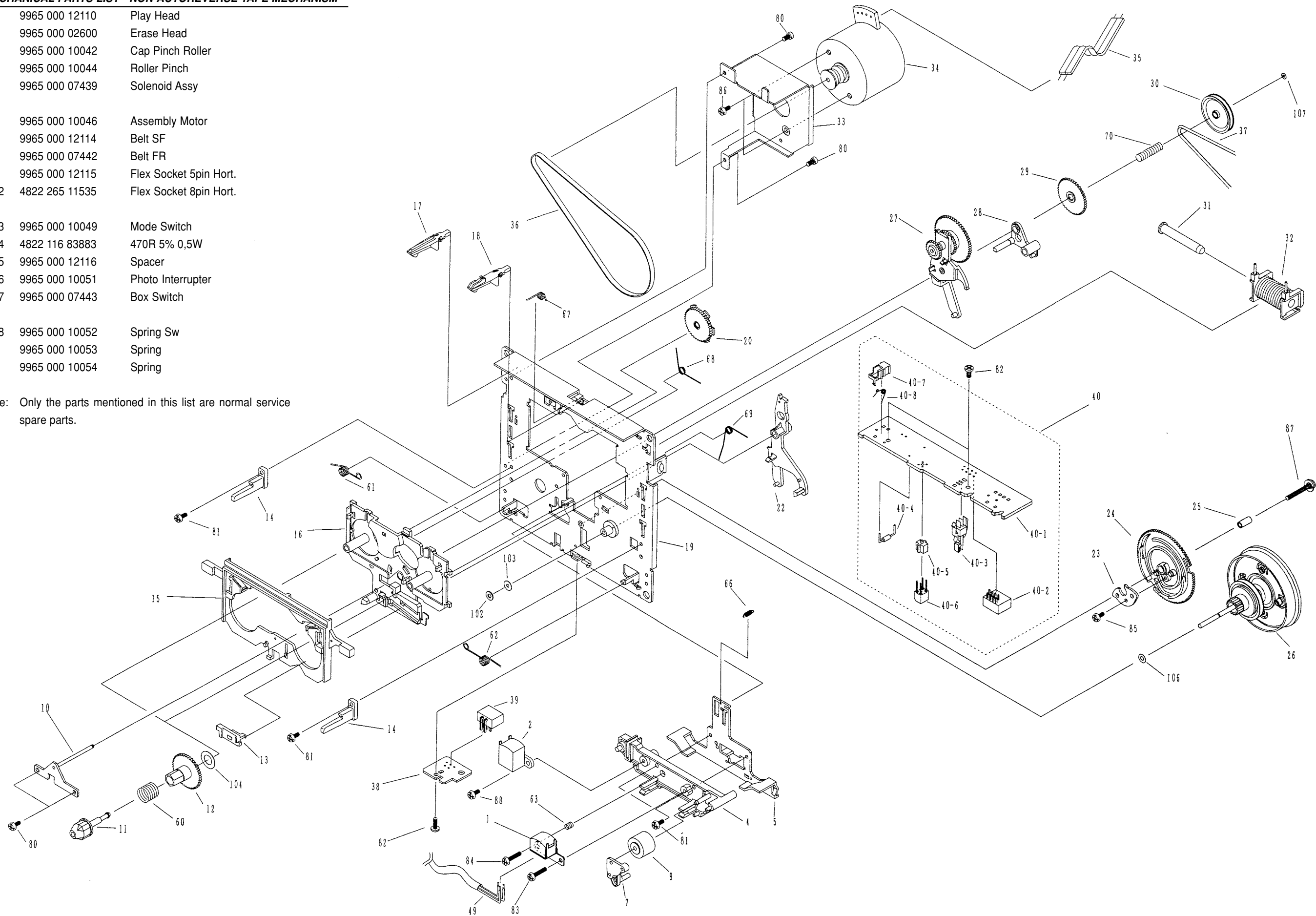

**TAPE MODULE EXPLODED VIEW**

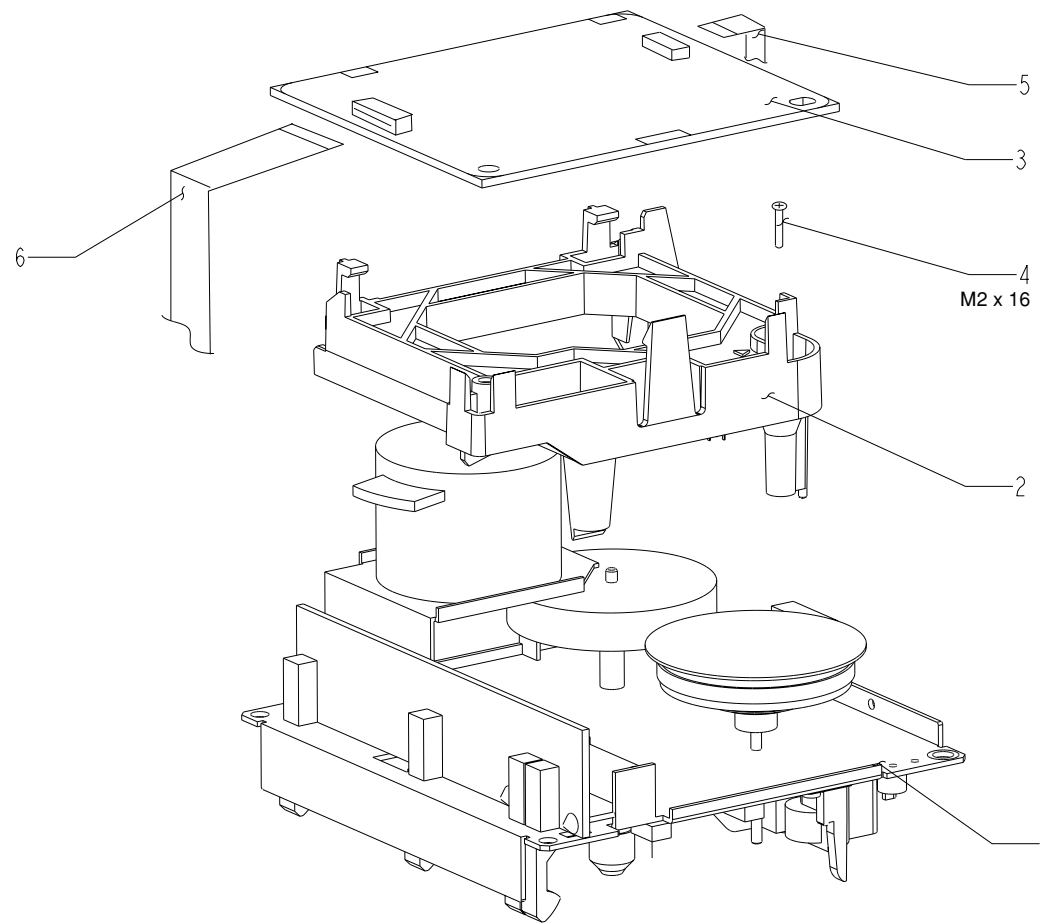

ETF8 SD Exploded view ....78730 dd wk204

**MECHANICAL PARTS LIST - TAPE MODULE**

1	3139 118 78740	AR Tape Mech. CRL4438
1	3139 118 79220	Non-AR Tape Mech. CFL4217
5	3139 110 35580	Flex Cable 5pin 40mm AD
6	3139 110 35590	Flex Cable 8pin 48mm AD

Note: Only the parts mentioned in this list are normal service spare parts.

**ELECTRICAL PARTS LIST - ETF8 BOARD**

**MISCELLANEOUS**

1701	4822 267 10953	Flex Socket 7pin Vert.
1706	4822 267 10953	Flex Socket 7pin Vert.
1710	4822 267 10958	Flex Socket 5pin Hort.
1760	4822 265 11535	Flex Socket 8pin Hort.

**CAPACITORS**

2621	5322 126 11578	1nF 10% 50V
2622	4822 126 13881	470pF 5% 50V
2623	4822 126 13881	470pF 5% 50V
2625	4822 126 14305	100nF 10% 16V
2701	4822 122 31765	100pF 2% 63V
2702	4822 122 31765	100pF 2% 63V
2703	4822 122 31765	100pF 2% 63V
2704	4822 122 31765	100pF 2% 63V
2709	5322 126 11578	1nF 10% 50V
2710	5322 126 11578	1nF 10% 50V
2711	4822 122 31765	100pF 2% 63V
2712	4822 122 31765	100pF 2% 63V
2713	5322 121 42386	100nF 5% 63V
2714	5322 121 42386	100nF 5% 63V
2715	4822 124 41584	100uF 20% 10V
2716	4822 124 41584	100uF 20% 10V
2717	3198 017 31530	15nF 50V
2718	3198 017 31530	15nF 50V
2721	3198 017 41050	1uF 10V
2722	3198 017 41050	1uF 10V
2723	4822 126 14238	2,2nF 50V
2724	4822 126 14238	2,2nF 50V
2725	4822 126 13883	220pF 5% 50V
2727	4822 126 14238	2,2nF 50V
2728	4822 126 14238	2,2nF 50V
2729	4822 126 14494	22nF 10% 25V
2730	4822 126 14494	22nF 10% 25V
2731	5322 126 11578	1nF 10% 50V
2732	3198 017 41050	1uF 10V
2743	4822 126 14494	22nF 10% 25V
2747	4822 126 14549	33nF 16V
2761	4822 124 40196	220uF 20% 16V
2768	4822 124 40756	1uF 20% 100V
2769	4822 126 14238	2,2nF 50V
2770	4822 126 14238	2,2nF 50V
2780	4822 124 81151	22uF 50V
2781	5322 126 11583	10nF 10% 50V
2782	4822 126 13193	4,7nF 10% 63V
2784	4822 121 51305	15nF 10% 50V
2785	4822 124 21913	1uF 20% 63V
2786	4822 122 31765	100pF 2% 63V
2787	4822 126 14549	33nF 16V
2788	4822 126 14494	22nF 10% 25V
2789	4822 126 14549	33nF 16V
2790	4822 126 14247	1,5nF 50V
2791	4822 126 14247	1,5nF 50V

2793	4822 126 13883	220pF 5% 50V
2794	4822 126 13883	220pF 5% 50V
2796	4822 124 40433	47uF 20% 25V
2797	4822 124 81151	22uF 50V
2798	4822 124 21732	10uF 20% 25V
2799	4822 126 14305	100nF 10% 16V

**RESISTORS**

3607	4822 051 30222	2k2 5% 0,062W
3608	4822 051 30273	27k 5% 0,062W
3609	4822 051 30222	2k2 5% 0,062W
3610	4822 051 20124	120k 5% 0,1W
3611	4822 051 30222	2k2 5% 0,062W
3612	4822 051 30563	56k 5% 0,062W
3614	4822 051 30273	27k 5% 0,062W
3624	4822 117 13632	100k 1% 0,062W
3626	4822 051 30102	1k 5% 0,062W
3628	4822 117 13632	100k 1% 0,062W
3630	4822 051 30471	470R 5% 0,062W
3678	4822 117 12925	47k 1% 0,063W
3680	4822 117 12925	47k 1% 0,063W
3686	4822 117 13632	100k 1% 0,062W
3709	4822 051 30339	33R 5% 0,062W
3710	4822 051 30339	33R 5% 0,062W
3711	4822 051 30101	100R 5% 0,062W
3712	4822 051 30101	100R 5% 0,062W
3717	4822 117 11817	1k2 1% 1/16W
3718	4822 117 11817	1k2 1% 1/16W
3723	4822 051 30183	18k 5% 0,062W
3723	4822 051 30223	22k 5% 0,062W
3724	4822 051 30183	18k 5% 0,062W
3724	4822 051 30223	22k 5% 0,062W
3733	4822 051 30273	27k 5% 0,062W
3734	4822 051 30273	27k 5% 0,062W
3735	4822 051 30223	22k 5% 0,062W
3736	4822 051 30223	22k 5% 0,062W
3737	4822 051 30102	1k 5% 0,062W
3738	4822 051 30102	1k 5% 0,062W
3739	4822 117 12925	47k 1% 0,063W
3740	4822 117 12925	47k 1% 0,063W
3743	4822 051 30563	56k 5% 0,062W
3744	4822 051 30563	56k 5% 0,062W
3745	4822 117 11817	1k2 1% 1/16W
3746	4822 117 11817	1k2 1% 1/16W
3749	4822 051 30121	120R 5% 0,062W
3750	4822 051 30121	120R 5% 0,062W
3762	4822 117 12968	820R 5% 0,62W
3764	4822 051 30181	180R 5% 0,062W
3768	4822 051 30103	10k 5% 0,062W
3769	4822 051 30223	22k 5% 0,062W
3769	4822 051 30183	18k 5% 0,062W
3770	4822 051 30152	1k5 5% 0,062W

AR  
AR

AR  
AR  
AR  
Non-AR  
AR  
Non-AR  
AR  
Non-AR  
AR  
Non-AR

**ELECTRICAL PARTS LIST - ETF8 BOARD****RESISTORS**

3771	4822 117 11817	1k2 1% 1/16W	
3772	4822 051 30153	15k 5% 0,062W	AR
3772	4822 051 30123	12k 5% 0,062W	Non-AR
3774	4822 051 30183	18k 5% 0,062W	
3775	4822 117 13608	4,7R 5% 0,063W	
3776	4822 051 30682	6k8 5% 0,062W	
3777	4822 051 30151	150R 5% 0,062W	
3778	4822 052 10688	6R8 5% 0,33W	
3779	4822 051 30334	330k 5% 0,062W	
3780	4822 051 30105	1M 5% 0,062W	
3781	4822 051 30475	4M7 5% 0,062W	
3786	4822 051 30223	22k 5% 0,062W	
3789	4822 117 12925	47k 1% 0,063W	
3790	4822 051 30223	22k 5% 0,062W	
3791	4822 051 30273	27k 5% 0,062W	
3796	4822 051 30475	4M7 5% 0,062W	
3797	4822 051 30563	56k 5% 0,062W	
3800	4822 051 30223	22k 5% 0,062W	
4701	4822 051 30008	0R Jumper 0603	
4702	4822 051 30008	0R Jumper 0603	
4705	4822 051 30008	0R Jumper 0603	
4707	4822 051 30008	0R Jumper 0603	
4708	4822 051 30008	0R Jumper 0603	
4709	4822 051 30008	0R Jumper 0603	
4710	4822 051 30008	0R Jumper 0603	
4711	4822 051 30008	0R Jumper 0603	
4712	4822 051 30008	0R Jumper 0603	
4718	4822 051 30008	0R Jumper 0603	
4719	4822 051 30008	0R Jumper 0603	
4720	4822 051 30008	0R Jumper 0603	
4721	4822 051 30008	0R Jumper 0603	
4723	4822 051 30008	0R Jumper 0603	
4725	4822 051 30008	0R Jumper 0603	
4726	4822 051 30008	0R Jumper 0603	
4727	4822 051 30008	0R Jumper 0603	
4729	4822 051 30008	0R Jumper 0603	
4730	4822 051 30008	0R Jumper 0603	
4731	4822 051 30008	0R Jumper 0603	
4732	4822 051 30008	0R Jumper 0603	
4733	4822 051 30008	0R Jumper 0603	
4734	4822 051 30008	0R Jumper 0603	
4735	4822 051 30008	0R Jumper 0603	
4736	4822 051 30008	0R Jumper 0603	Non-AR
4737	4822 051 30008	0R Jumper 0603	Non-AR
4738	4822 051 30008	0R Jumper 0603	
4739	4822 051 30008	0R Jumper 0603	
4741	4822 051 30008	0R Jumper 0603	
4746	4822 051 30008	0R Jumper 0603	
4747	4822 051 30008	0R Jumper 0603	

**COILS & FILTERS**

5701	4822 157 62552	Coil 2,2uH 5%
------	----------------	---------------

5703	4822 156 20946	Osc Coil 100kHz
------	----------------	-----------------

**DIODES**

6612	4822 130 31878	1N4003G
6770	4822 130 30621	1N4148
6771	4822 130 30621	1N4148
6772	4822 130 30621	1N4148
6773	4822 130 30621	1N4148
6774	4822 130 30621	1N4148
6776	4822 130 30621	1N4148
6777	3198 010 58280	BZX79-B8V2
6778	4822 130 30621	1N4148

**TRANSISTORS & INTEGRATED CIRCUIT**

7610	5322 209 11306	HEF4094BT
7612	4822 130 11201	PMBT2907
7614	4822 130 11201	PMBT2907
7618	4822 130 60511	BC847B
7620	4822 130 60511	BC847B
7624	4822 130 60511	BC847B
7720	9322 167 09668	AN17150ATA
7780	4822 130 60511	BC847B
7781	4822 130 42804	BC817-25
7782	4822 130 44568	BC557B
7783	4822 130 60511	BC847B
7784	4822 130 60373	BC857B
7786	4822 130 63494	J111
7788	4822 130 60511	BC847B
7789	4822 130 60511	BC847B
7790	4822 130 60511	BC847B

Note: Only the parts mentioned in this list are normal service spare parts.